

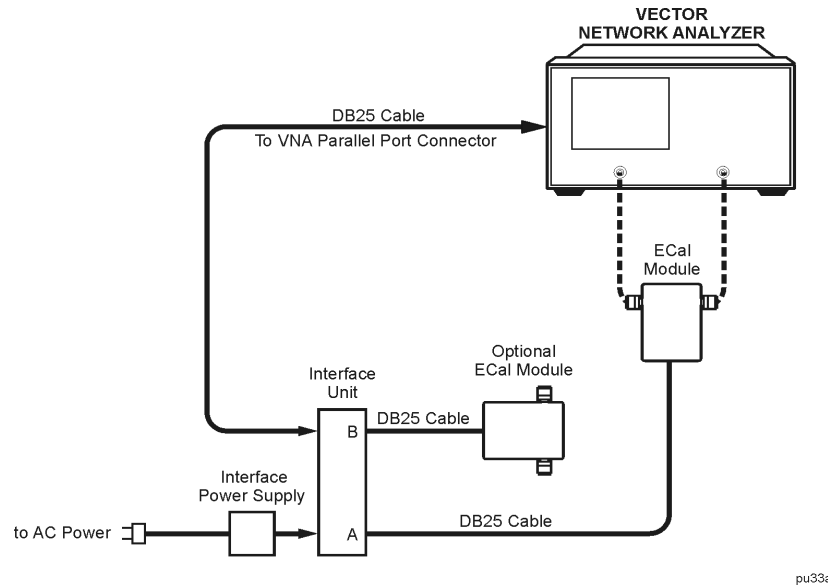

## VNA-Based System Setup Procedure



pu33a

### About the VNA-Based System

The VNA-based system uses the firmware of the vector network analyzer (VNA) to drive an electronic calibration through the Agilent 85097B VNA interface kit. Network analyzers that are compatible with the 85097B VNA interface kit are listed in the following table.

Agilent Network Analyzer	Firmware Revision
8719D/ES/ET	7.68 or higher
8720D/ES/ET	7.68 or higher
8722D/ES/ET	7.68 or higher
8753ES/ET	7.68 or higher

Refer to the setup diagram on this page for all connections.

### Connect Interface Unit to the VNA

1. Connect one end of an DB25 cable to the connector on the *interface unit* labeled “DB25 Interface to Parallel Interface on Network Analyzer.”

### CAUTION

**Be sure to use the Parallel Port on the VNA. Connecting the interface unit to the VNA Test Set Port connector WILL cause damage.**

2. Connect the other end of the DB25 cable to the *Parallel Port* connector on the rear of the VNA.

### Connect Interface Unit to the ECal Module

3. Connect one end of an DB25 cable to the connector on the *interface unit* labeled “DB25 Interface to ECal Module A.”
4. Connect the other end of the DB25 cable to the connector on the *ECal module*. If a second module is needed, connect the module to the interface unit labeled “DB25 Interface to ECal Module B.”

### Connect the Interface Unit Power Supply

5. Connect the interface power supply to the *interface unit* and then connect to AC power.
6. Allow the ECal modules to warm up before calibration. When Indicator the LED turns green, the module is ready to calibrate.
7. Refer to the VNA user’s guide for calibration procedures.